

SIVACON 8PT non-withdrawable-unit technology

General information

The SIVACON 8PT low-voltage switchgear is the FEAG standard solution for building and industry engineering. SIVACON 8PT has been tailored to meet the requirements of the global market, i.e. it takes into account the demand for single-source standard solutions. SIVACON 8PT is produced by FEAG as a power distributor for many customers around the world and can be used at all performance levels up to 6300 A and even above.

The panels for cable outputs in the non-withdrawable unit installation are equipped, according to requirements, with circuit breakers, fuse switch-disconnectors or switchable fuse switch-disconnectors.

These panels are used in applications where replacements under operating conditions are not necessary or where short standstills are acceptable.

Even in this case, the non-withdrawable unit installation of SIVACON offers good economic efficiency, safety and flexibility.



SIVACON 8PT low voltage switchgear

Modular construction

Each SIVACON 8PT is produced from standardised and typical modules. All modules are top quality because of the FEAG standard audit and design specifications. The numerous combination options of these modules enable all requirements to be met. The exclusive use of high quality Siemens switchgear guarantees long service life and reliable operation.

Inspections

Each SIVACON switchgear is subject to a routine test before delivery:

Checking switchgear combinations, including wiring and, if necessary, electrical function tests and insulation tests
Checking the safety measures and the continuous ground lead connection

The switchgear are type-tested (TTA), i.e. they meet the requirements for:

IEC 60 439-1

DIN EN 60 439-1

VDE 0660 Part 500

This is implemented by:

- Proof of compliance with temperature rise limits by testing
- Proof of insulation resistance by testing
- Proof of short-circuit strength by testing
- Proof of good connection between units in the switchgear assembly and the ground connection by checking or resistance measurements
- Nachweis der mechanischen Funktion
- Nachweis der IP-Schutzart

These tests guarantee a high level of operating and personal safety.

The safety requirements are also supported by a series of details in the SIVACON, for example:

- Utilisation of just several high quality insulating materials (e.g. for busbars, stiffners, etc.)
- Utilisation of high quality Siemens switchgear for long service life and minimum down times
- Safe disconnection after maximum 70 to 100 ms, even with high lag times, due to the 3W circuit breaker with ZSS (time-reduced discriminative control)
- DP-supported planning for precise selection and positioning of operating media
- Internal arc tested
- Effective quality management during entire FEAG production process

Panel construction

- In general, a panel is divided into five functional sections:
- Busbar section
- Device section
- Cable/bar connection section
- Cross-wiring section
- Cable riser section

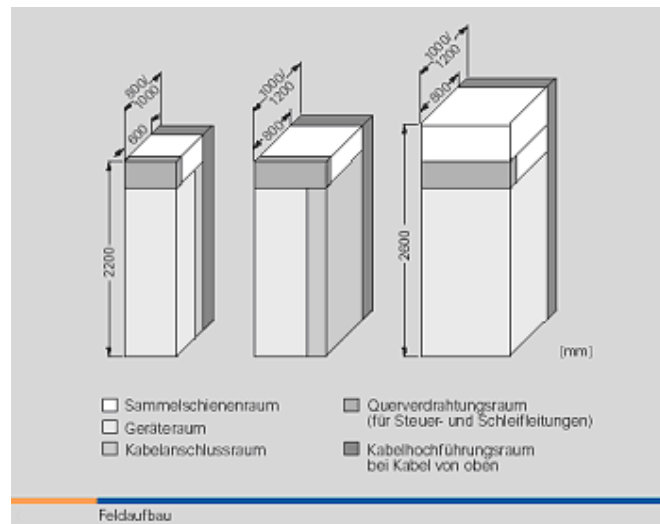

Characteristics

- Siemens switchgear for reliable operation
- Global availability
- High flexibility for economic solutions
- Large device section depth for universal installation
- Modular structure of device sub-sections
- Single front and back to back installation
- Cable entry from above or below
- Cable connection from front or back

Framework and enclosure

The framework, the supporting elements of the panel, consists of sturdy sheet steel profiles that are connected to each other. The precisely dimensioned and stable SIVACON framework is available either screwed or welded together.



Characteristics

- Continuous series of holes 25 mm apart for customised installation
- Flexible door layouts for all requirements
- Door opening angle up to 180°
- Sprung sash lock reliably prevents unintended door opening
- Roof panels with pressure relief
- Surface treatment: optional powder-coated, wet-painted, galvanised

Material

Framework and enclosure made of sheet steel with following thicknesses:

- Framework: 2.5 mm
- Enclosure: 2.0 mm
- Degree of protection as per IEC 60529 IP 30, IP 31, IP 40, IP41, IP 42 ventilated IP 40, IP 54 not ventilated

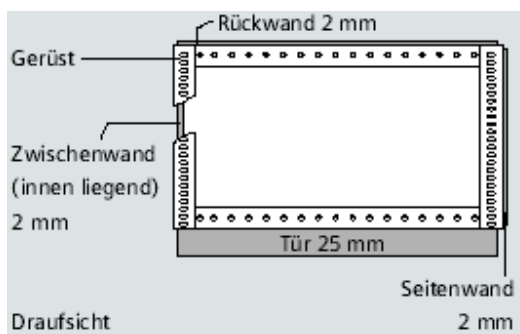
|  | | Feldhöhe (mm) | Feldbreite (mm) | Feldtiefe (mm) |
|---|--|---------------|---------------------------|----------------------|
| | | 2200 | 400, 600, 800, 1000, 1200 | 600, 800, 1000, 1200 |
| | | 2600 | 400, 600, 800, 1000, 1200 | 800, 1000, 1200 |

Variable busbar systems

The wide range of demands for busbar systems requires individual implementation options. SIVACON offers modules for economic construction with high security. The busbar system can be variably used and consists of the three external conductors L1 to L3 and the PE, N or PEN conductors.

Busbar position, top



Characteristics

- 3 and 4 pole busbar systems for rated currents up to 7400 A
- Practise-based adjustment of rated currents
- Rated peak withstand current I_{pk} up to 375 kA
- Separation between busbar section and device section
- Transport unit connection points easily accessible from above
- Arc barriers for internal arcing reduction

| Bemessungsströme bei 35 °C Umgebungstemperatur | | | | | |
|---|------------|----------|-------------------|----------|-----------------|
| Außenleiter (L1, L2, L3), Anzahl, Maße (mm) | unbelüftet | belüftet | I_{pk} / I_{cw} | Feldhöhe | Feldtiefe |
| 2 x 100 x 10 | 2400 | 3200 | 200/80 | 2200 | 600, 800, 1000 |
| 3 x 100 x 10 | 2950 | 4000 | 250/100 | 2200 | 800, 1000, 1200 |
| 3 x 100 x 10+ 3 x 100 x 10 | 5400 | 7400 | 375/150 | 2600 | 800, 1000, 1200 |

Busbar position, rear

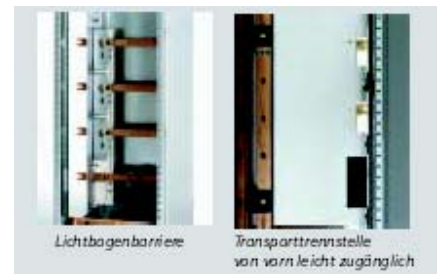
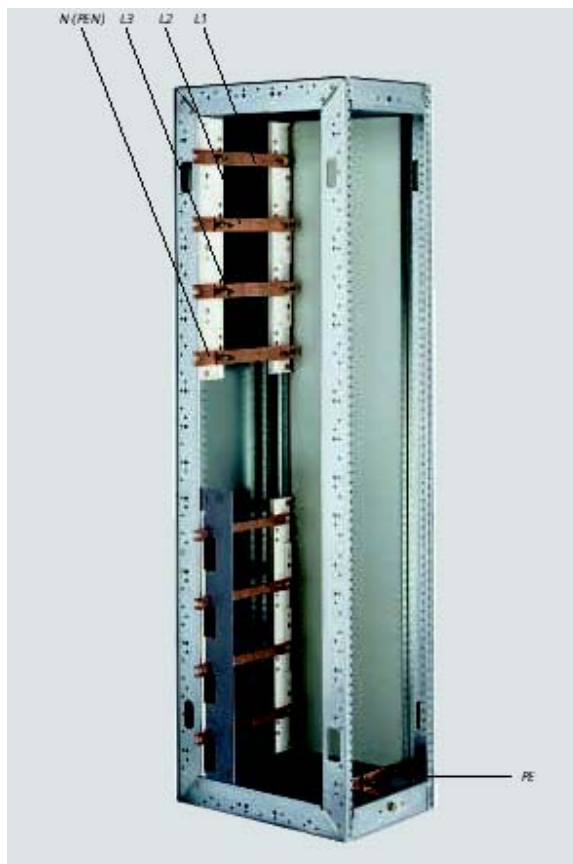

Characteristics

- 3 and 4 pole busbar systems for rated currents up to 3200 A
- Practise-based adjustment of rated currents
- Rated peak withstand current I_{pk} up to 187 kA
- Separation between busbar section and device section
- Two busbar systems can be run into the switchgear
- Transport unit connection points easily accessible from the front
- No maintenance busbar connections
- Arc barriers for internal arcing reduction (optional)

| Bemessungsströme bei 35 °C Umgebungstemperatur | | | |
|--|-----------------|---------------|-----------------------|
| Außenleiter (L1, L2, L3), Anzahl, Maße (mm) | unbelüftet A | belüftet A | I_{pk}/I_{cw} kA |
| 1 x 30 x 10 | 810 | 990 | 52,2 / 25 |
| 1 x 40 x 10 | 950 | 1160 | 52,5 / 25 |
| 1 x 60 x 10 | 1240 | 1510 | 143 / 65 |
| 2 x 40 x 10 | 1600 | 1990 | 143 / 65 |
| 2 x 60 x 10 | 1830 | 2300 | 187 / 85 |
| 2 x 80 x 10 | 2060 | 2590 | 187 / 85 |
| 2 x 100 x 10 | 2280 | 2900 | 187 / 85 |

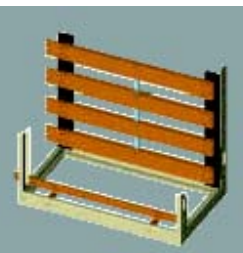

Cable outputs in modular construction

The modular cable outputs enable economic installation. Changes or modifications due to operational requirements are easy to implement.

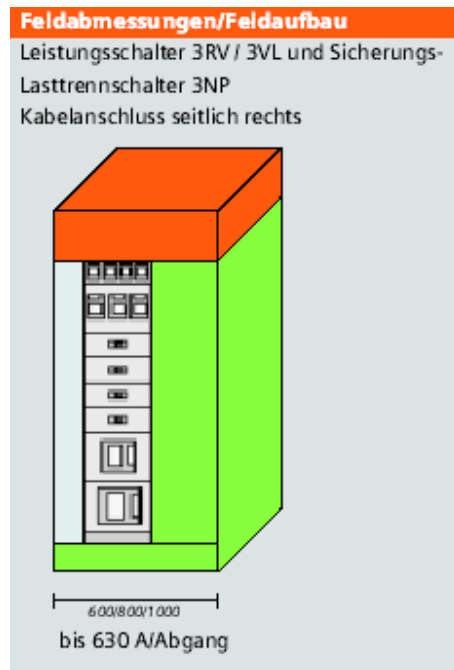
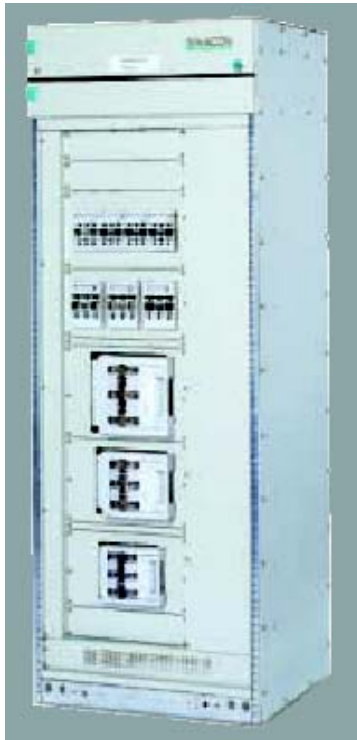

Characteristics

- Circuit breakers or fuse switch-disconnectors can be inserted where required
- Free combination of cable outputs within a panel
- Infinitely adjustable device carriers for uniform front level
- Cable outputs with and without current measurement
- Displays and operation with closed doors

Cable outputs in compartment technology

Compartment technology with individual compartment formation for each circuit breaker provides greater active security for system and personal protection.

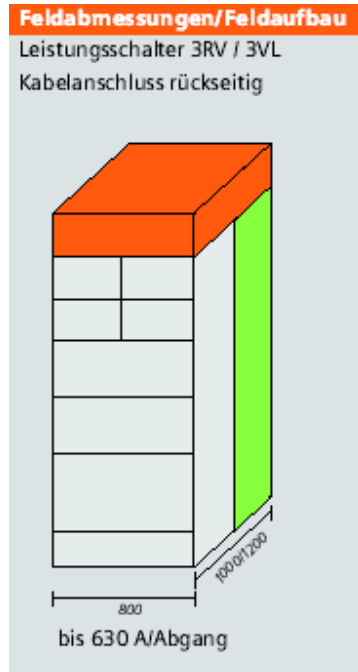

Characteristics

- Individual compartments with door for each circuit breaker
- Circuit breaker 3VL with or without socket
- High form of internal division up to Form 4 Type 7 as per BS EN 60439 (gland box per function unit)
- Optimum connection conditions in rear cable connection section
- High security through type-tested standard modules (TTA)
- Any combination of cable outputs in modular design and compartment technology
- Easy replacement of cable outputs when switchgear is isolated

Strip technology 3NJ4 – permanent installation:

The panels for cable outputs in permanent installation are equipped with switchable strip-type fuse switch-disconnectors. The fuse switch-disconnectors offer optimal installation conditions with their compact and modular structure. These panels are used in applications where replacements under operating conditions are not necessary. In this case, the permanent installation of SIVACON offers good economic efficiency, safety and flexibility.

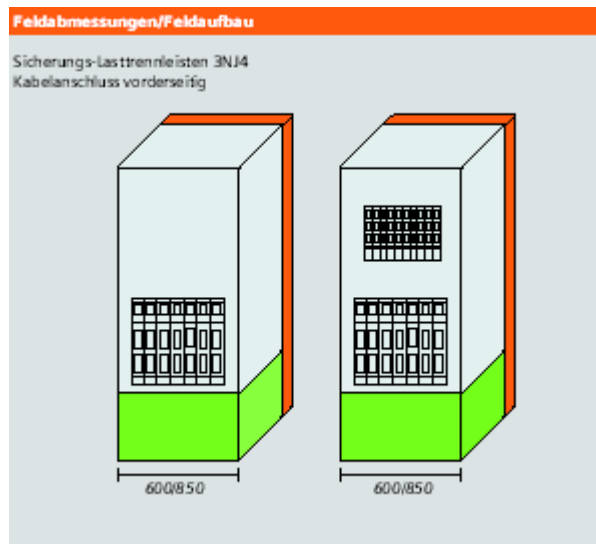

Characteristics

- High security through type-tested standard modules (TTA)
- Cable outputs up to 630 A with/without current measurement
- Dependent on size, a maximum of 24 outputs per panel can be installed
- Isolated fuse replacement
- Doors available with or without door cut-outs
- Optional installation of quick-fit modules and strip-type fuse switch-disconnectors up to 160 A (operation behind doors)

Switchable strip-type fuse switch-disconnectors

The strip-type fuse switch-disconnectors offer optimal installation conditions with their compact and modular structure.

- Cable outputs up to 630 A with/without current measurement
- Dependent on size, a maximum of 25 outputs per panel can be installed
- Isolated fuse replacement



Feldabmessungen/Feldaufbau

Sicherungs-Lasttrennleisten 3NJ4

Kabelanschluss seitlich rechts

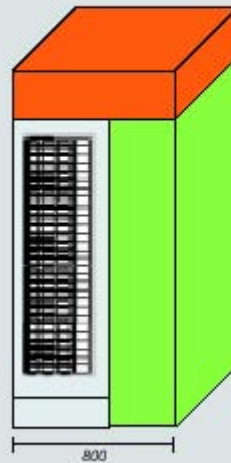

bis 160 A/Abgang

Kabelanschluss unten

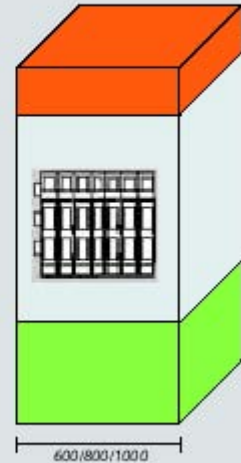

bis 630 A/Abgang

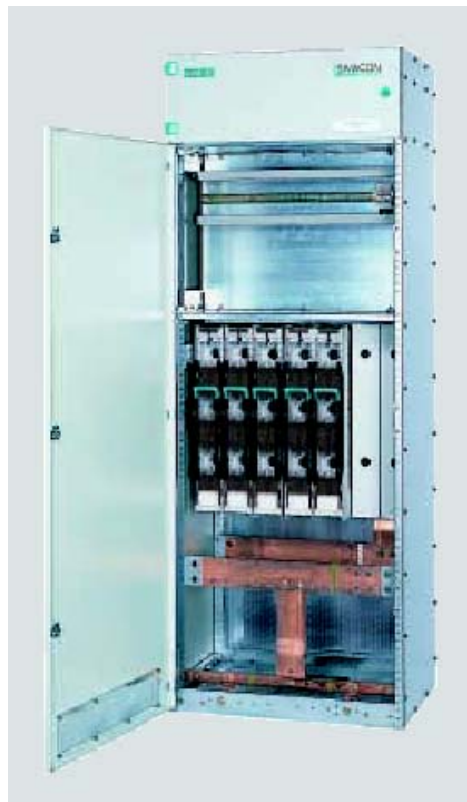

Application example

Power distribution

This circuit breaker technology includes panel types that are exclusively used for supplying the switch gear, as well as for outputs and couplings. Various panel variants are available dependent on the function, device rated current and necessary short-circuit strength.

The strip-type fuse switch-disconnectors offer optimal installation conditions with their compact and modular structure.

Feed, output and coupling panels in circuit breaker technology are equipped with ACB-circuit breakers 3W in permanent installation. As these panels are normally upstream of numerous loads, they have a particular importance with regards to long-term operating and personal safety of the switchgear. SIVACON meets these requirements with the circuit breaker technology components.

Siemens circuit breakers, series 3W, are used with permanent installation for the rated current range from 630 to 6300 A.

This means:

- Free selection of feed direction without restricting the technical data
- High short-time current load rating for time-selective short-circuit protection up to 400 ms ensures safe operation of the system components not affected by the short-circuit case
- Short-circuit protection with time-reduced discriminative control (ZSS) at very short lag times (maximum 70 to 100 ms) independent of the number of staggered grades.
- LCD operating current display in control panel (without ammeter and transformer)
- Displays and operation with closed doors

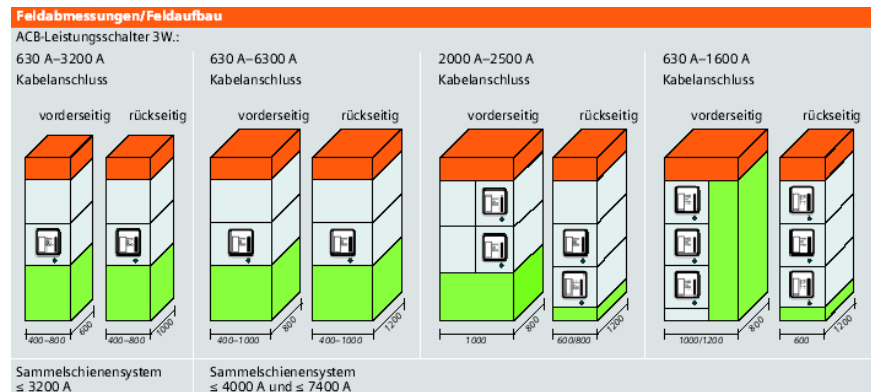

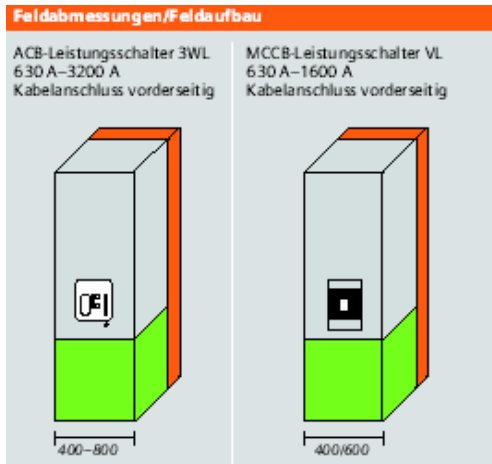

Characteristics

- Compact and safe
- High security through type-tested standard modules (TTA)
- Test and disconnected position with closed door
- Switches integrated in separate compartments; individual compartment doors available
- Optimum connection conditions for every rated current range
- Cable connection from below or above
- User-friendly with 3W

| Technical data | Sizes | Values |
|--|------------------------------------|--|
| Rated electrical strength | | 8kV |
| Overvoltage category | | III |
| Degree of contamination | | 3 |
| Rated isolation voltage | | 1000 V |
| Rated operating voltage | | up to 690 V |
| Main busbar, horizontal | Rated current | up to 7400 A |
| | Rated peak withstand current | up to 375 kA |
| | Rated short-time withstand current | up to 150 kA, 1 s |
| Busbars, vertical for permanent installation | Rated current | up to 1400 A |
| | Rated peak withstand current | up to 163 kA |
| | Rated short-time withstand current | up to 65 kA, 1 s |
| Device rated currents | Circuit breaker | up to 6300 A |
| | Cable outputs | up to 630 A |
| Inner subdivision | Form 1 to 4 | IEC 60439-1, Section 7.7 DIN EN 60439-1 |
| Framework elements | | Galvanised Powder-coated Wet painted |
| Cladding | | Galvanised Powder-coated Wet painted |
| Doors | | Galvanised Powder-coated Wet painted |
| Degree of protection | As per IEC 60529, EN 60529 | IP 30 to IP 54 |
| Dimensions | | H: 2200, 2600 mm W: 400 to 1200 mm D: 600 to 1200 mm |

Application example

Reactive power compensation

The panels for central reactive power compensation relieve transformers and cables, reduce transmission losses and save energy costs. Dependent on the load structure, they are equipped with capacitor modules with or without impedance.



Controller module with electronic reactive power controller for door installation

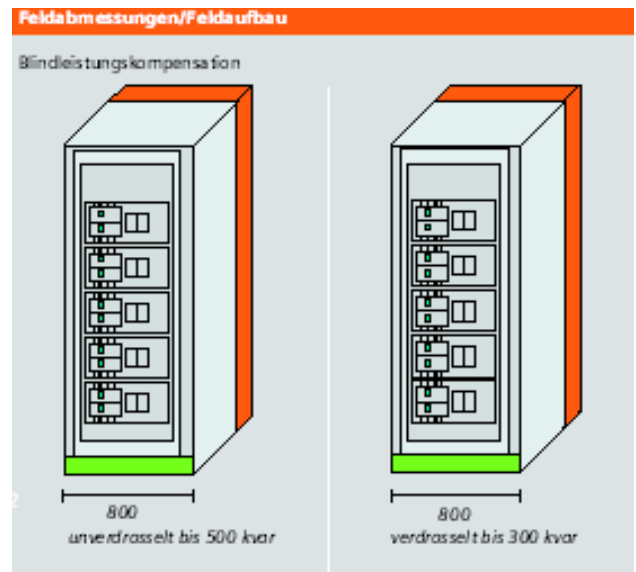

Characteristics

- Multi-function display
- Automatic C/k value setting
- Adjustable nominal $\cos \phi$ from 0.8 ind to 0.98 cap
- Manual/automatic operation of capacitor module up to 100 kvar
- Fuse switch-disconnector
- Capacitor switching contactor
- MKK capacitors
- Discharge devices
- Filter reactors (with impedance capacitor modules)

| Technical data | Sizes | Values |
|--|------------------------------------|--|
| Rated electrical strength | | 8kV |
| Overvoltage category | | III |
| Degree of contamination | | 3 |
| Rated isolation voltage | | 1000 V |
| Rated operating voltage | | up to 690 V |
| Main busbar, horizontal | Rated current | up to 7400 A |
| | Rated peak withstand current | up to 375 kA |
| | Rated short-time withstand current | up to 150 kA, 1 s |
| Busbars, vertical for permanent installation | Rated current | up to 1400 A |
| | Rated peak withstand current | up to 163 kA |
| | Rated short-time withstand current | up to 65 kA, 1 s |
| Device rated currents | Circuit breaker | up to 6300 A |
| | Cable outputs | up to 630 A |
| Inner subdivision | Form 1 to 4 | IEC 60439-1, Section 7.7 DIN EN 60439-1 |
| Framework elements | | Galvanised Powder-coated Wet painted |
| Cladding | | Galvanised Powder-coated Wet painted |
| Doors | | Galvanised Powder-coated Wet painted |
| Degree of protection | As per IEC 60529, EN 60529 | IP 30 to IP 54 |
| Dimensions | | H: 2200, 2600 mm W: 400 to 1200 mm D: 600 to 1200 mm |

Application example

Free planning

Various add-on components are available for the free planning of panels for e.g. control and regulation tasks. The panels for free planning are designed for the installation of devices with snap-on systems, as well as for unfused and fused cable outputs up to 630 A.

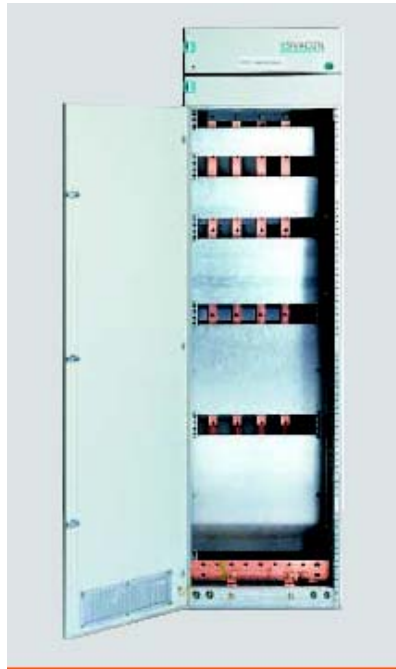

Characteristics

- High security through type-tested standard modules (TTA)
- Numerous add-on components
- Infinitely adjustable device carriers for uniform front level
- Front panels or doors with or without inspection glass
- Busbar system, 3 and 4 pole
- Panel-high doors or compartment doors
- Compartment formation
- Numerous add-on components

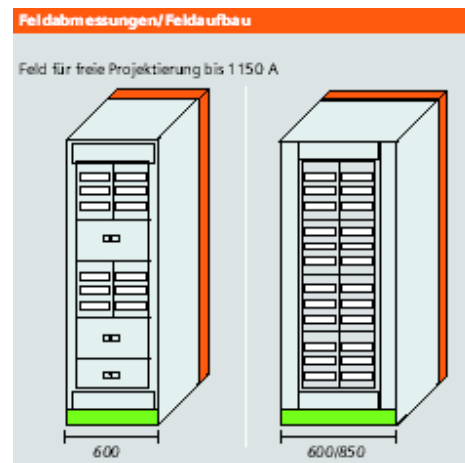

| Technical data | Sizes | Values |
|--|------------------------------------|--|
| Rated electrical strength | | 8kV |
| Overvoltage category | | III |
| Degree of contamination | | 3 |
| Rated isolation voltage | | 1000 V |
| Rated operating voltage | | up to 690 V |
| Main busbar, horizontal | Rated current | up to 7400 A |
| | Rated peak withstand current | up to 375 kA |
| | Rated short-time withstand current | up to 150 kA, 1 s |
| Busbars, vertical for permanent installation | Rated current | up to 1400 A |
| | Rated peak withstand current | up to 163 kA |
| | Rated short-time withstand current | up to 65 kA, 1 s |
| Device rated currents | Circuit breaker | up to 6300 A |
| | Cable outputs | up to 630 A |
| Inner subdivision | Form 1 to 4 | IEC 60439-1, Section 7.7 DIN EN 60439-1 |
| Framework elements | | Galvanised Powder-coated Wet painted |
| Cladding | | Galvanised Powder-coated Wet painted |
| Doors | | Galvanised Powder-coated Wet painted |
| Degree of protection | As per IEC 60529, EN 60529 | IP 30 to IP 54 |
| Dimensions | | H: 2200, 2600 mm W: 400 to 1200 mm D: 600 to 1200 mm |